

INSTRUCTION MANUAL

ELECTRIC MULTIPLE NEEDLE SCALER

Please read this manual carefully before you attempt to use your tool so that you may use it properly and safely.

JET CHISEL Model EJC-32A PROFESSIONAL TOOL



Specifications

Model		EJC-32A 115V	EJC-32A 230V
Power Source (Single Phase)	V AC	110-120 50/60 Hz	220-240 50/60 Hz
Rated Power Consumption	W	300	
	A	2.8	1.4
Rated Time	min	30	
Stroke Speed	No Load	min ⁻¹ 3000	
Needle		O.D.3X180	
Mass (Weight)	kg	4.5	
Sound Pressure Level	No Load	84.6	
	Load	84.9	
Sound Power Level	No Load	95.6	
	Load	95.9	
Vibration Level [Uncertainty K]	Body	m/s ² [m/s ²] 16.8 [2.2]	
	Handle	14.8 [2.6]	

Due to continuous product development/improvement the specifications and configurations in this document are subject to change without prior notice.



Manufactured by:

NITTO KOHKI Co., Ltd.
2-9-4, Nakaikegami, Ohta-ku,
Tokyo, 146-8555, Japan
Tel : (81)-3-3755-1111
Fax : (81)-3-3753-8791
E-mail : overseas@nitto-kohki.co.jp
URL : www.nitto-kohki.co.jp

Keep the manual handy - so you can use it whenever necessary.

Original Instructions

Thank you very much for your purchase of this **Nitto Kohki products**.







Before using your tool, please read this manual carefully so that you may use it properly to get the most out of it.

Please keep the manual handy - so you can use it whenever necessary.

- **English** : Please ask your dealer or distributor for instruction manual in local language(s).
- **German** : Bitte fragen Sie Ihren Händler nach eine Betriebsanleitung in Landessprache.
- **French** : S'il vous plait, veuillez demandez á votre fournisseur de manuel instruction en langue locale.
- **Spanish** : Por favor, contacte con su distribuidor para el manual de instrucciones en español.
- **Portuguese** : Por favor pessa ao seo agente ou distribuidor o manual de instrucces ih linguagen local.
- **Italian** : Per Manuale Istruzioni in lingua locale Vi preghiamo di rivolgervi al rivenditore o distributore.
- **Dutch** : Vraag uw handelaar om een nederladstalige gebruiksaanwijzing.
- **Swedish** : Be er lokala Åtreförsäljare eller distributör om manualer pá svenska.
- **Danish** : Venligst henvend Dem til den danske distributør for instructions manualer.
- **Polish** : Proszę pytać swojego dealera lub dystrybutora o instrukcje obsługi w języku localnym.
- **中文** : 請向當地供應商或經銷商詢問中文使用說明書



CONTENTS	page
IMPORTANT SAFETY INSTRUCTIONS FOR ALL ELECTRIC TOOLS	
1. USAGE	3
2. CHECK THE CONTENTS OF THE PACKAGE	3
3. NAME OF PART	3
4. CAUTION FOR USE	3
5. PREPARATION	3
6. HOW TO OPERATE THE TOOL	4
7. MAINTENANCE AND INSPECTION	4
8. OPTIONAL ACCESSORIES	6
9. ORDERING SERVICE PARTS	6

PICTOGRAM

-  Warning: It might be dangerous to operate the tool if the instructions supplied are not followed.
-  Using this tool improperly could result in serious injury. Read the instruction manual before use.
-  Always wear suitable eye protection.
-  Always wear suitable hearing protection.
-  Always wear respiratory protective equipment (PPE).
-  Always wear protective gloves for protection of hands from Vibration and Shock

Storage Temperature : -10°C~60°C (no freezing)
 Storage Humidity : Maximum 90% at 25°C (no dewing)
 Operating Temperature : 5°C~40°C
 Operating Humidity : Maximum 90% at 25°C (no dewing)
 Altitude : 1000m Max.
 Over-voltage Category : Category II according to IEC60664-1
 Pollution Degree : Degree 3 according to IEC60664-1

The following Safety notations are used throughout the manual to highlight safety precautions for the user and for the tool.

 WARNING:	Indicates a potentially hazardous situation which, if not avoided by following the instructions given, could result in death or serious injury.
 CAUTION:	Indicates a potentially hazardous situation which, if not avoided by following the instructions given, could result in injury or material damage.

Please note, however, that failure to observe safety precautions under the “ **Caution**” category could result in a serious occurrence depending on the situation: please observe all safety precautions in the manual.

Caution: Important precautions for tool setup, operation and maintenance.

WARNING

IMPORTANT SAFETY INSTRUCTIONS FOR ALL ELECTRIC TOOLS

When using electric tools, basic safety precautions should always be followed to reduce risk of fire, electric shock, personal injury and the like, including the following.

(1) Keep work area clean. Cluttered work areas and benches invite accidents and injuries.

(2) Consider work area environment. Do not expose tools to rain. Do not use tools in damp or wet locations. Keep work area well lit. Do not operate near flammable liquids or in gaseous or explosive atmospheres.

(3) Be cautious about electric shock. When using electric tools, do not touch any which is earthed. (Ex. Pipe, heating apparatus, microwave oven, outside frame of refrigerator)

(4) Keep children away. Also all visitors should be kept away from work area. Do not let visitors contact the tool, compressor or connecting hoses.

(5) Store idle tools. When not in use, tools should be stored in dry, and locked-up places out of reach of children.

(6) Do not force tool. It will do the job better and safer at the rate which it was designed.

(7) Use right tool. Do not force a small tool of attachment to do the job of a heavy-duty tool. Do not use tool for a purpose not intended.

(8) Dress properly. Do not wear loose clothing or jewelry. They can be caught in moving parts. Non-skid rubber gloves and footwear are recommended. Wear protective hair covering to contain long hair.

(9) Always wear eye protection. Everyday eyeglasses only have impact resistant lenses. They do NOT protect eyes. Also use face or dust mask, if operations create dust.

(10) Do not abuse cable. Never carry tool by connecting cable or yank on hose to disconnect. Do not place a cable near a place with high heat, oil, and sharp edge.

(11) Secure work. Use clamps or a vise to hold work when practical. It is safer than using your hand and it frees both hands to operate tool.

(12) Do not overreach. Keep proper footing and balance at all times.

(13) Cautious maintenance is necessary for electric tools.
· Always maintain blades and keep it to work well so that safe and efficient work can be done.

· Follow the instruction manual for oiling or change of accessories.

· Check the cable regularly. Contact the sales agents to repair it when it is defective.

· When an extension cable is used, check regularly and change it when it is damaged.

· The grip should be kept dry and clean. Maintain it so well that it does not carry oil or grease.

(14) Switch off and take off the plug for the following:

· Not in use

· When you change blades, grinding stone and bit

· Any danger is anticipated.

(15) Make sure that spanners, wrenches etc. which are used for adjustment are removed before switching on.

(16) Always avoid unexpected start.

· Do not carry the tool with a finger on the switch when the power supply is on.

· Make sure that the switch is off before plugging in.

(17) Use a cabtyre cable or a cabtyre extension cable when it is used outside.

(18) Stay alert.

Watch what you are doing. Bear in mind the way of handling/operation and the circumstances of the surrounding area.

Use common sense.

Do not operate tool when you are tired.

(19) Check damaged parts.

· Before further use of the tool, an accessory or other part that is damaged should be carefully checked to determine that it will operate properly and perform its intended functions.

· Check for alignment of moving parts, binding of moving parts, breakage of parts, mounting and any other conditions that may affect its operation. An accessory or other part that is damaged or inoperable should be properly repaired or replaced. When a switch becomes out of order, repairs should be performed only by the sales agent from whom you purchased the tool.

· Do not use electric tools which cannot be activated or stopped with a switch.

(20) Use recommended accessories.

Consult this manual or the sales agent from whom you purchased the tool or our company for recommended accessories. The use of improper accessories may cause risk of injury to persons.

(21) Repairs by authorized personnel.

· This tool should not be modified as it meets safety requirements.

· Any repairs to the tool or installation of replacement parts should be performed only by the sales agent from whom you purchased the tool or our company. Use only genuine replacement parts.

· Failure to utilize the expertise of an authorized sales agent from whom you purchased the tool or our company or, failure to use genuine replacement parts, may result in an increased risk of injury to the user and may invalidate your warranty.

1 USAGE

This is an electric hand-held fast multiple needle scaler for scaling workpieces such as slags and spatters.

2 CHECK THE CONTENTS OF THE PACKAGE

Check the contents and make sure that the tool does not have any damage due to an accident during the transportation, if any. The contents should correspond to the list as follows. Just in case there are some damages or missing parts, contact the sales agent from whom you purchased the tool or an authorized dealer.

THE CONTENTS OF THE PACKAGE AND ACCESSORIES

Package Contents	Q'ty	check
ELECTRIC NEEDLE SCALER	1	
Needle 3 ϕ \times 180	15	
Hex. Socket Screw Key 6	1	
Instruction Manual	1	

3 Names of Part

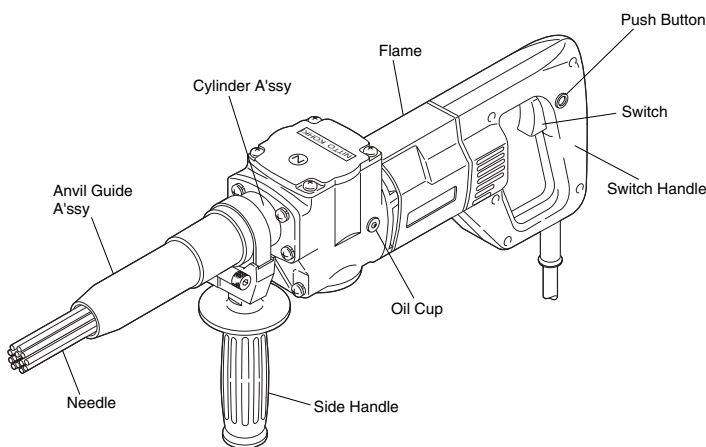

4 Caution for Use

⚠ WARNING

- Use of power is limited to the power specified by the rating plate.
- Check to see that the earth leakage breaker is installed. Even when using power supply in which the earth leakage breaker is set, it should be used after grounding for the purpose of more safety.
- Note that power cord which is too long may cause a voltage drop. Do not use another electric tool together.

Extension Cable	
max. Length	Sectional Area
20 m	0.75 mm ² Over
30 m	1.25 mm ² Over
50 m	2 mm ² Over

- When performing maintenance, inspection, replacement or adjustment of parts, make sure to disconnect the attachment plug from the receptacle.
- Do not remove a rating plate. Please contact sales agent for replacement if they are taken off or damaged.
- If you feel discomfort or pain while using this tool, stop using it and have a doctor examine you.
- Check if it conforms to noise regulation in the area.
- Do not operate it without any work as it may cause some damage on the head of Needles. [Fig 1]

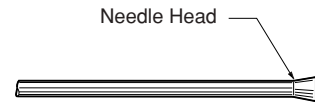

[Fig 1]

5 PREPARATION

⚠ WARNING

When the preparation is made, switch off and take off the plug.

5-1 How to fix a Side Handle [Fig. 2]

Put the Holder Cover on the Handle Holder and fix it at an arbitrary position with a Side Handle.

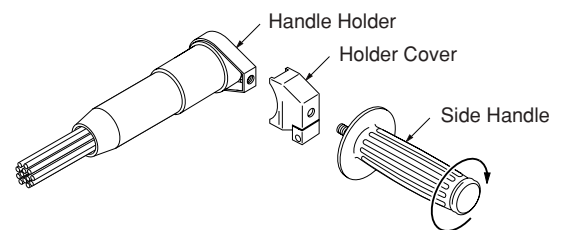

[Fig 2]

5-2 How to change a Needle [Fig 3]

To remove: Loosen the Hex. Socket Cap Screw with Hex. Socket Screw Key and take out an Anvil Guide Ass'y from the Cylinder Ass'y. The Needles with the Needle Supporter can be removed. Replace them with the new ones.

To fix: Fix them without any clearance at A. The procedure is the opposite of the removal.

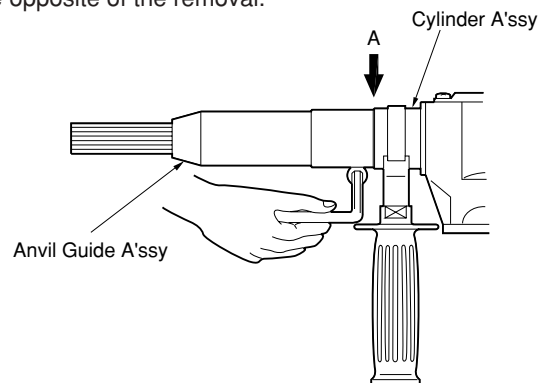

[Fig 3]

6 HOW TO OPERATE THE TOOL

⚠ WARNING

Always wear eye protection. Everyday eyeglasses only have impact resistant lenses. They do not protect eyes. Also use face or dust mask, if operation creates dust.

6-1 Start And Stop

⚠ WARNING

Always switch off before it is plugged in.

① Depress the Trigger Switch in the direction of "ON" in the Switch Handle. The Needles work. When the button in the Switch Handle is pressed, the operation switch is locked (on). [Fig 4]

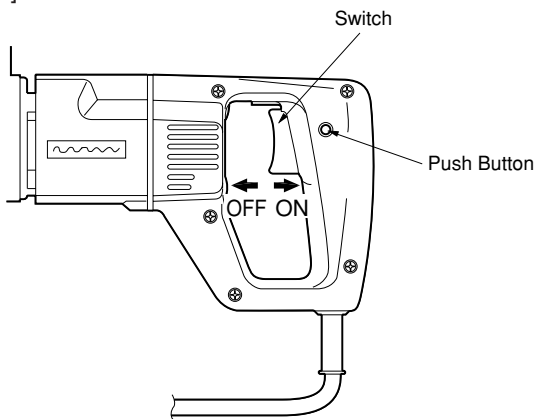

[Fig 4]

② When the work is completed, keep the hand apart from the operation switch and make it off. When the operation switch is locked, pull it once again to unlock.

- It is not necessary to press the tool against the work. It is good enough to support it so that Needles are in the right track of the operation.
- When it is operated with pressure more than necessary, it may cause the Needle bent/broken or the tool damaged.
- Needles are consumable. When even one piece is broken, stop the operation promptly, take the left head of the Needle and substitute a new one for it. If the operation continues with the Needle head left, it will cause in the early stage the damage of the Needle Supporter and abnormal operation.

7 MAINTENANCE AND INSPECTION

⚠ WARNING

When performing maintenance, inspection, replacement or adjustment of parts, make sure to disconnect the attachment plug from the receptacle.

Check regularly if there is any place where fixed screw becomes loose. If there is some, fasten again.

7-1 Oiling [Fig 5]

Before use and 3~4 hours after start of the operation, never fail to oil about 1cc of machine oil #10 from the opening of the Anvil Guide. If dense oil is used, it may cause malfunction.

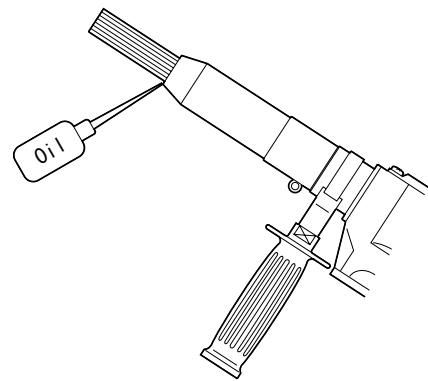

[Fig 5]

7-2 Grease pouring [Fig 6]

Grease is used in the Gear. It should be poured with a grease gun from an Oil Cup once a month.

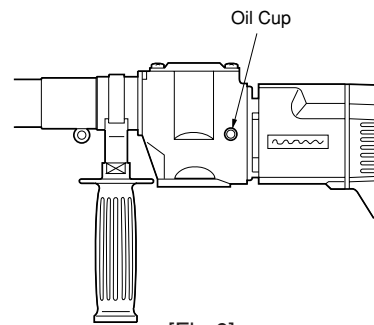

[Fig 6]

7-3 Replacement of Fuse [Fig 7]

A Fuse is installed in the Handle to prevent overload to the Motor. When the Fuse is cut, get rid of the cause. Then, replace it with a new one.

● Procedure

- ① Loosen five screws and remove the Switch Handle(A).
- ② Take out a Fuse Holder which is packed with Sponge and replace it with a new one.
- ③ Replace it with a new Fuse which is specified by Nitto Kohki. The procedure is the opposite of the removal.

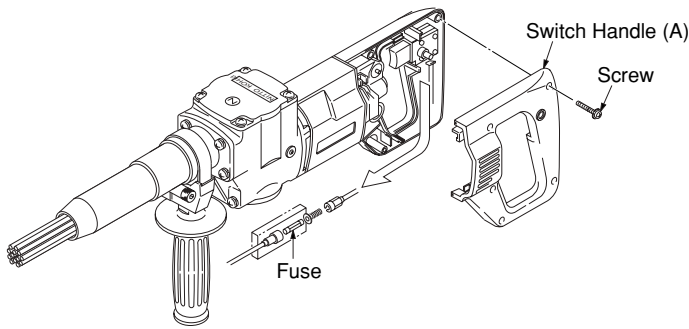

[Fig 7]

7-4 Inspecting and Replacing Carbon Brushes

The tool must be run under no load for at least ten minutes after Carbon Brushes have been replaced.

- Wears on the Carbon Brushes need to be checked regularly.
- When they have worn down to about 6mm, the commutation deteriorates and may cause a breakdown, so they should be replaced with the new ones in accordance with the following procedure.[Fig 8]

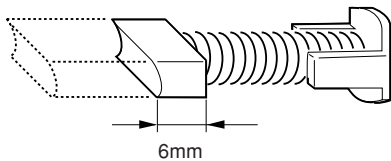

[Fig 8]

● Removal

- ① Completely loosen the Switch Handle fastening screws and remove Switch Handle(A).[Fig 9]

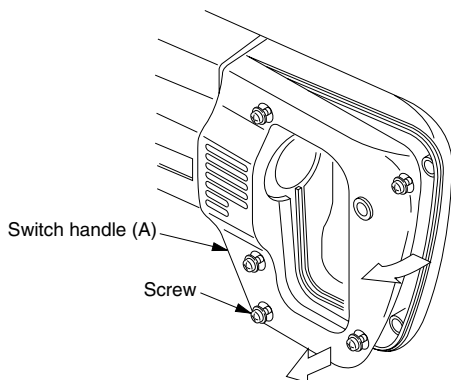

[Fig 9]

- ② Slide the Brush Holder Retainer to the back of the Motor (towards the two Core Rods) and push gently to release the Brush Holder Retainer diagonally from the slider. You can now lift up the Brush Holder Retainer and take it out. [Fig 10]

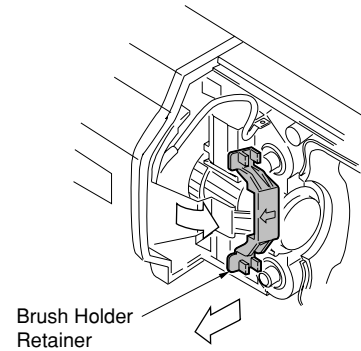

[Fig 10]

- ③ Lift the Brush Holder with a screwdriver and press the Carbon Brush as you remove it. [Fig 11]

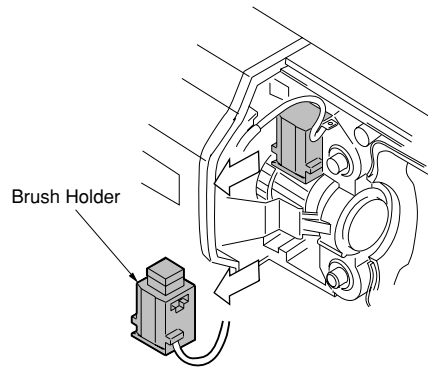

[Fig 11]

● Replacement

- ① Disconnect the lead wire from the brush terminal and remove the brush.[Fig 12]
- ② With the terminal insert side of the new brush aligned with the opening in the Brush Holder, insert the new brush and insert the lead wire terminal into the brush.[Fig 12]

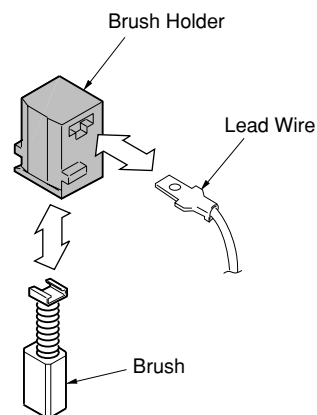

[Fig 12]

Assembly

① Insert the Brush Holder into the Frame with the chamfered edge to the front.

Note: If it is difficult to get the lead wire terminal into the Brush Holder, insert the terminal a little obliquely.[Fig 13]

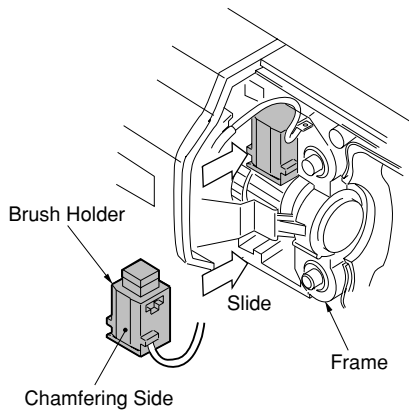

[Fig 13]

② With the arrow marked on the Brush Holder Retainer pointing towards Frame, insert it obliquely as shown in Fig 14.

③ The Brush Holder Retainer can be set horizontally if you push it in the direction of the arrow on the Brush Holder Retainer. Slide it as far as possible in the direction of the arrow.[Fig 14]

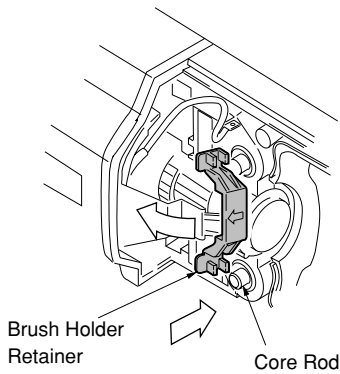

[Fig 14]

④ Put the lead wire in the groove in the Brush Holder Retainer so that it does not become caught in the Motor.[Fig 15]

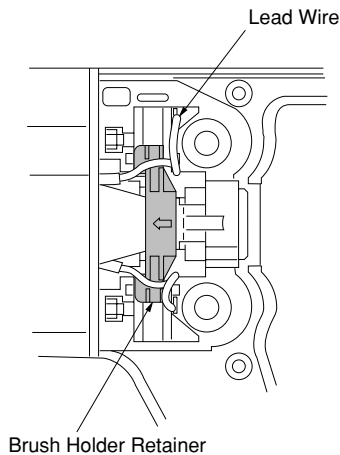

[Fig 15]

⑤ Press Switch Handle(A) into the Frame while you fit the Core Rods and complete the assembly.

[Fig 16]

⑥ Tighten the Switch Handle fastening screws.

[Fig 16]

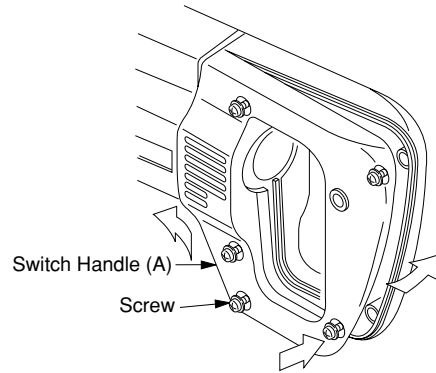

[Fig 16]

8 OPTIONAL ACCESSORIES

Parts No.	Parts Name	Q'ty
TP16475	Needle Supporter 2 ϕ	1
TA98781	Needles 2 $\phi \times 180$	100pcs.
TA98782	Needles 3 $\phi \times 180$	100pcs.

9 ORDERING SERVICE PARTS

In ordering parts and components, give the part number, part name and quantity to the sales agent from whom you purchased the tool.